

# Implantable Shunt Regulation Device and Shunt System: Externally controllable shunt regulation system

## Background & Innovation

Up to now, **shunts**, passages that allow movement of fluid from one part of the body to another, can not be **adjusted externally regarding the fluid flow**.

In ventricular assist devices (**VAD**) a **shunt** is combined with a pump so blood can be passed from the heart ventricle into the efferent blood vessel. In the case of pump malfunctions, a **retrograde flow** can occur via the **shunt** which worsens the already poor hemodynamics of the patient.

Our **externally controllable shunt regulation system** can **prevent retrograde flow**.

Up to now, **adaptation of shunts in growing children** require timeconsuming surgeries that are an additional burden for the children. Our **shunt regulation system** allows **non invasive adaptation** of flow on account of child growth.

Furthermore, **shunt systems** are adapted during surgeries to the **intraoperative hemodynamic** of the patient, which can differ from the postoperative situation. Our new technologies overcomes this problem. The **shunt**, hence the flow, can be **adapted anytime externally with our shunt regulation device**.

## Technical Description

The concept is based on an electrically driven tube pinch valve configured in a manner that the valve is able to pinch a flexible shunt tube or body vessel.

The flow cross-section of the shunt tube can be adjusted externally via a wireless connection.

- In case of **pump malfunction** the **shunt** can be **closed**.
- **Infants**: flow through the shunt can be adapted to **changing needs** due to **growth**.
- Shunt and hence the flow can be adapted to **post-operative situation**.

## Potential Applications

- Upgrade VADs **prevent retrograde** flow in case of **pump malfunctions**
- **Non-invasive** shunt **adaptation** during **growth of children**
- **Shunt adaptation** to **post-operative situation**

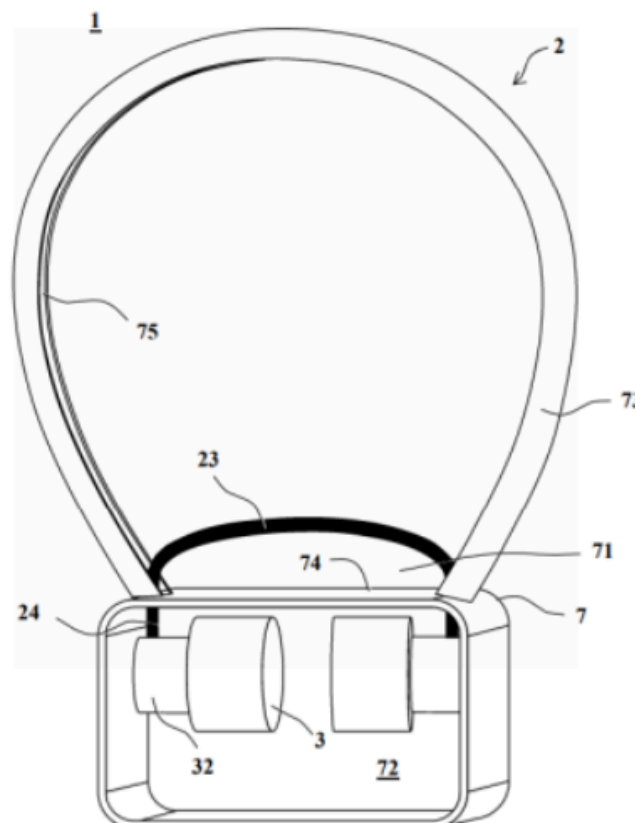

One embodiment of a shunt regulation device: a shunt or body vessel is passed through the opening 71 and the cross- section of the shunt or vessel is reduced (or enlarged) in order to reduce (or enlarge) the fluid flow through the tube or vessel by tightening or loosening the wire sling 23.

## FOCUS SECTORS

- Medtech
- VAD patients
- Shunt regulation
- Shunts in infants

## PROJECT KEY WORDS

- VAD
- Shunt adaptation

## DEVELOPMENT STATUS

- Proof of concept

## PATENT PROCEDURE STATUS

- EP Patent granted
- US Patent pending

## POTENTIAL FOR COOPERATION

- R&D Cooperation
- Licensing
- Transfer of rights



Contact Data:  
**Tutech Innovation GmbH**

✉ [pva.ip@tutech.de](mailto:pva.ip@tutech.de)

☎ +49 40 76629-6587

**UKE Technology Transfer Office**

✉ [medigate-transfer@uke.de](mailto:medigate-transfer@uke.de)